

### Toilet Paper Origami: Diamond Fold

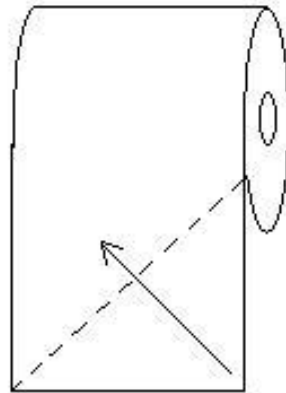

1

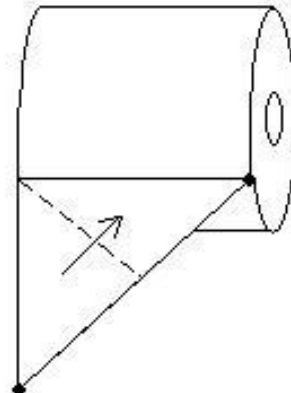

2

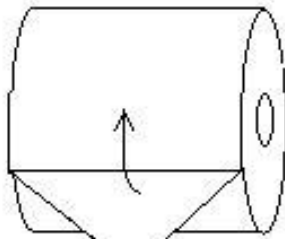

3

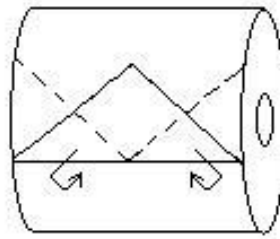

4

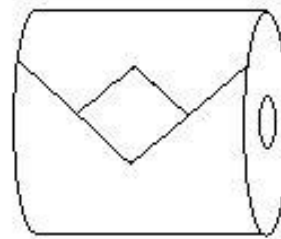

5



With the toilet paper still attached to the roll, pull out about 2 or 3 squares worth of TP and let it hang down.

Fold the bottom right corner up towards the left to form a right-angled triangle.

Join point A to point B by folding the bottom left corner up to form an isosceles triangle.

Flip the triangle upwards and rest it on the TP roll. Fold the bottom left and bottom right corners under. Adjust the folds so that the diamond is centered.

Press down firmly to re-enforce the creases. Done!

**Next Toilet Paper Origami: Pleated Fold**

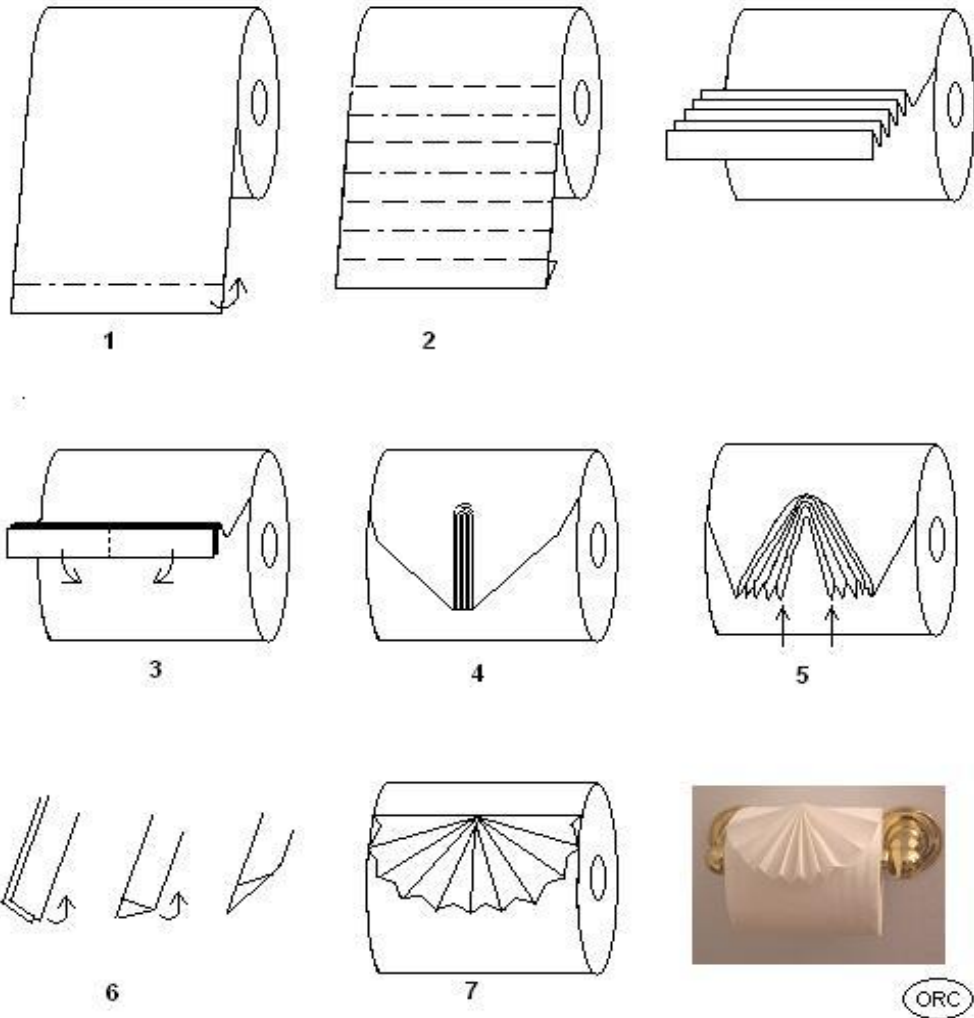

With the toilet paper still attached to the roll, pull out about 2 or 3 squares worth of TP and stretch it towards you. Fold raw edge under about ½".

Continue to fold the TP in an up-and-down, accordion fashion. Make at least 7 to 10 folds, the more the better. Compress the pleats into a tight stack.

Fold the stack of pleats in half towards you.

Squeeze the stack together pressing the creases firmly.

Release the stack of pleats and allow the folds to relax. Find the two pleats that are closest to one another (shown with arrow). Expanded view; only two layers shown: Hold the two layers closest to one another and fold the corner to form a small triangle. Fold this corner once more to lock the two halves together.

Gently layer the pleated TP onto the roll. Arrange and fluff the TP until you have an inverted fan-like structure.

**Next Toilet Paper Origami: Pleated Tuck**

### Toilet Paper Origami: Pleated Tuck

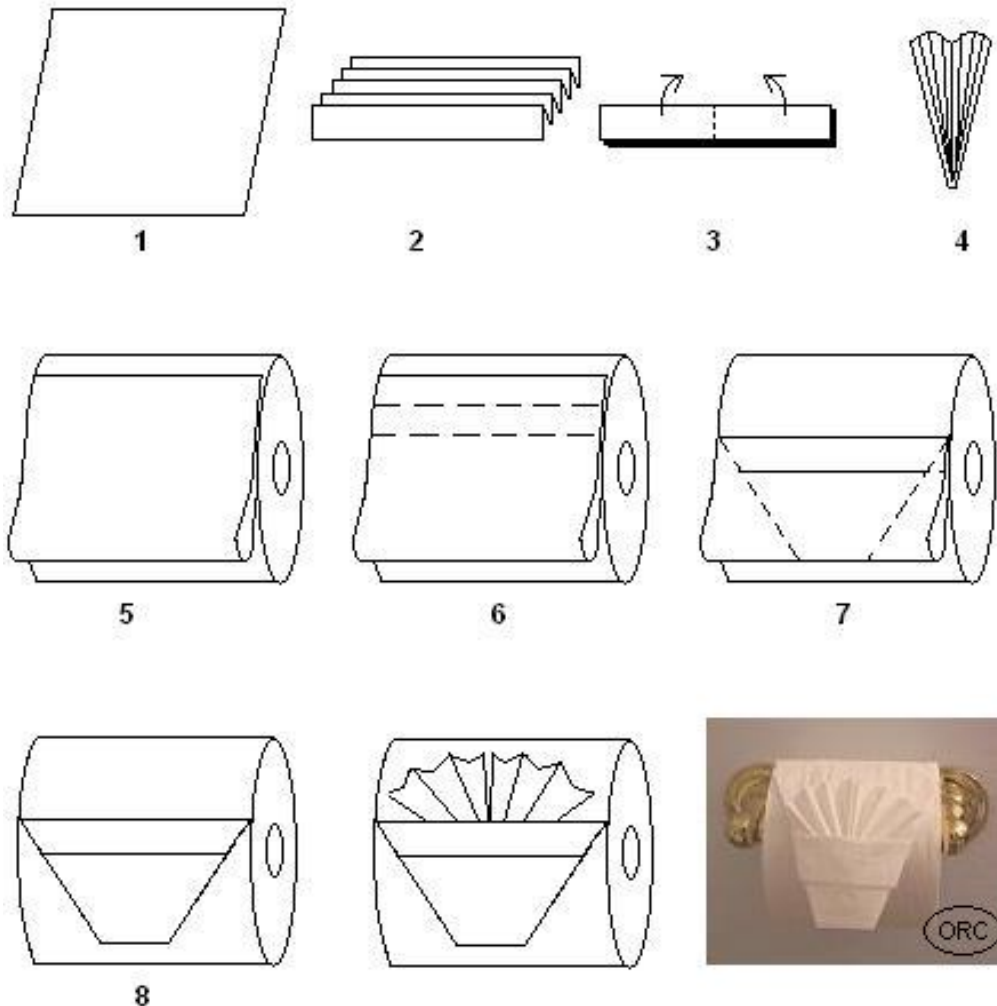

Rip off one square sheet of TP. Fold this sheet in an up-and-down accordion fashion.  
Compress the pleats into one stack. Fold the stack of pleats in half.  
Set aside and allow the pleats to unfold slightly.

With the toilet paper still attached to the roll, pull out about 2 or 3 squares worth of TP  
and lay it on top of the roll. Fold the raw edge over twice (about one inch in width).  
This hides the raw edge and forms a border.

Fold the bottom left and bottom right corners under. Adjust the angle so that the basket-  
like structure is even and symmetrical.

Tuck in the stack of pleats made as shown above to the  
basket formed in step 8...Done!